

Audio  
Power  
Board

API Confidential  
No Copy/Reproduction Allowed

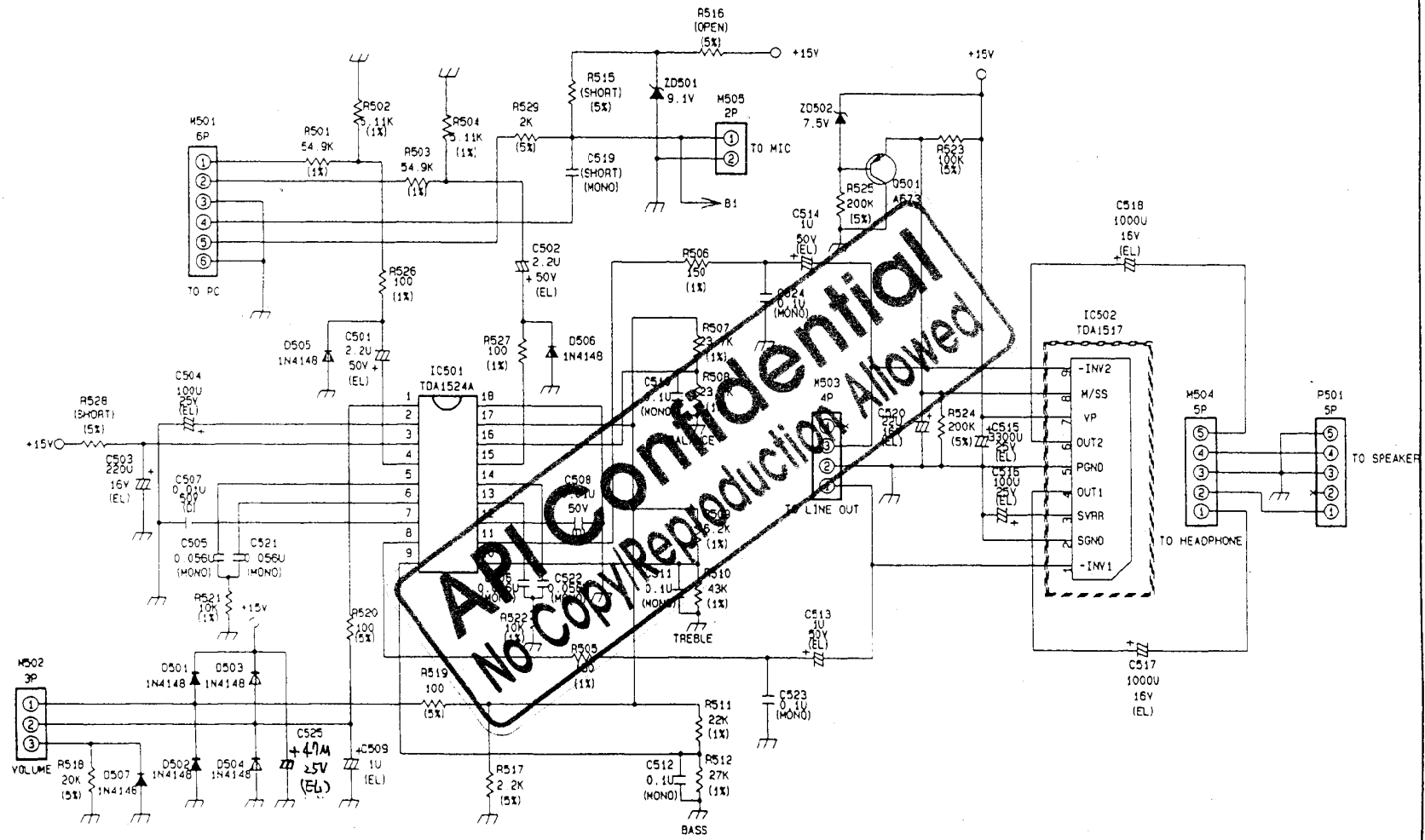

**明基電腦股份有限公司**  
**Acer Peripherals, Inc.**

ACERVIEW 7133S/7155S/7134TS/7176IS (AUDIO, BD) SCHEMATICS

SIZE A4	33SAU1-D.SCH	FAB 0	304-C03	REV. 5
------------	--------------	----------	---------	-----------

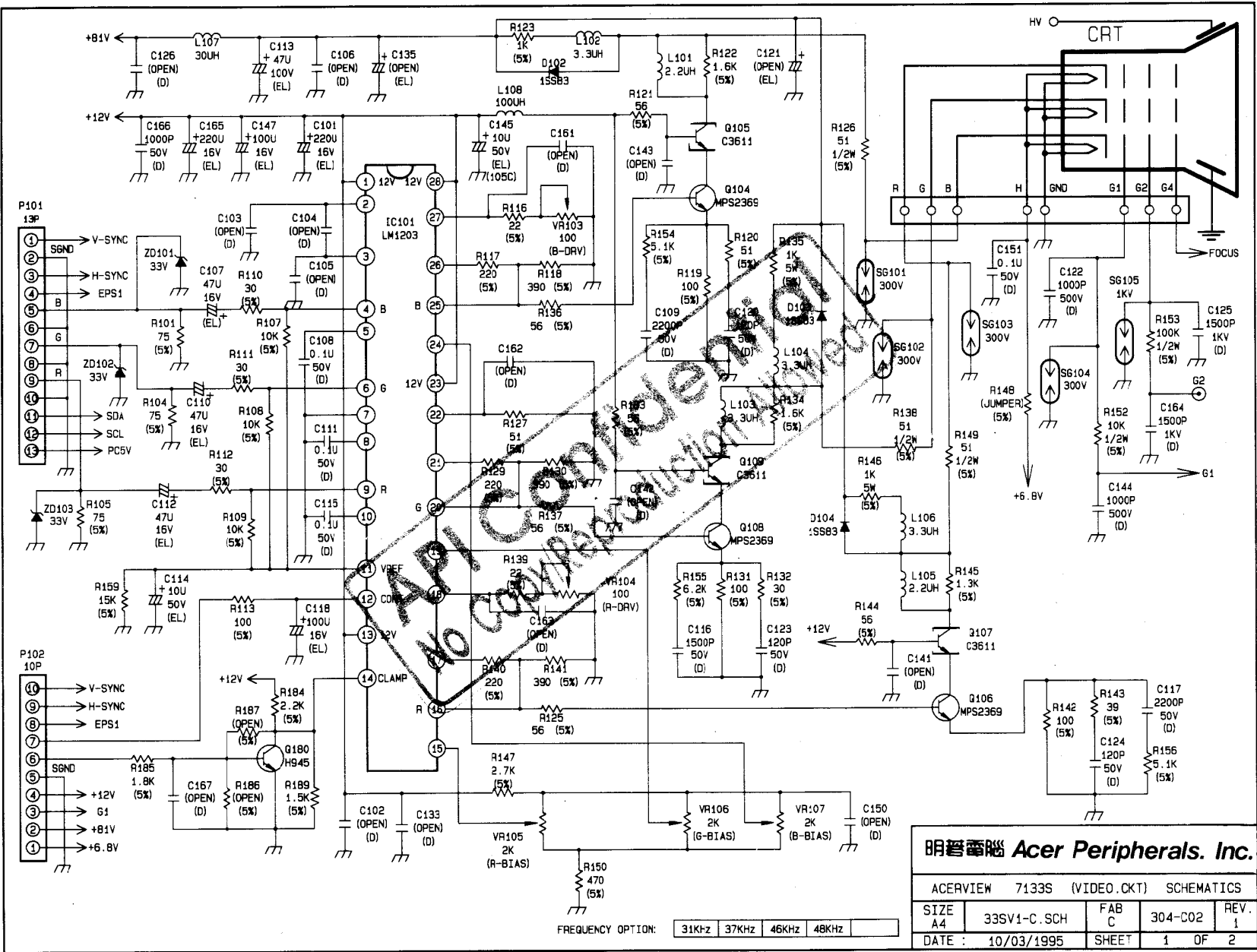

**明普電腦 Acer Peripherals. Inc.**

ACERVIEW 7133S (VIDEO.CKT) SCHEMATICS			
SIZE A4	33SV1-C.SCH	FAB C	304-C02
DATE : 10/03/1995	SHEET	1	OF 2

FREQUENCY OPTION: 31KHz 37KHz 46KHz 48KHz

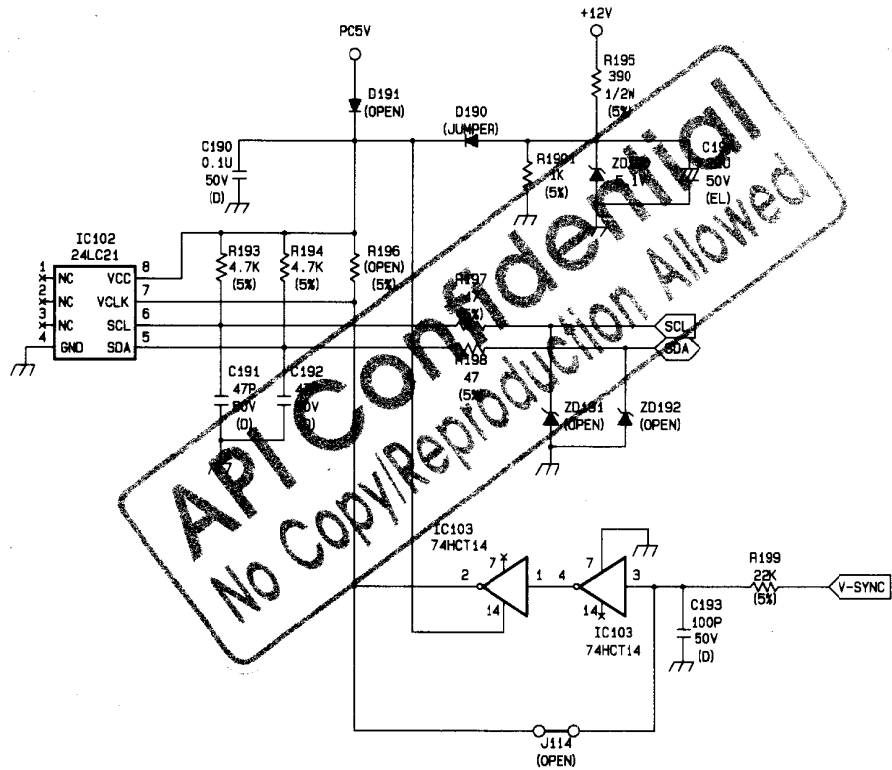

API Confidential  
 No Copy/Reproduction Allowed

<b>明碁電腦 Acer Peripherals. Inc.</b>				
ACERVIEW 7133S (DDC.CKT) SCHEMATICS				
SIZE A4	33SV2-C.SCH	FAB C	304-C02	REV. 1
DATE :	10/03/1995	SHEET	2	OF 2

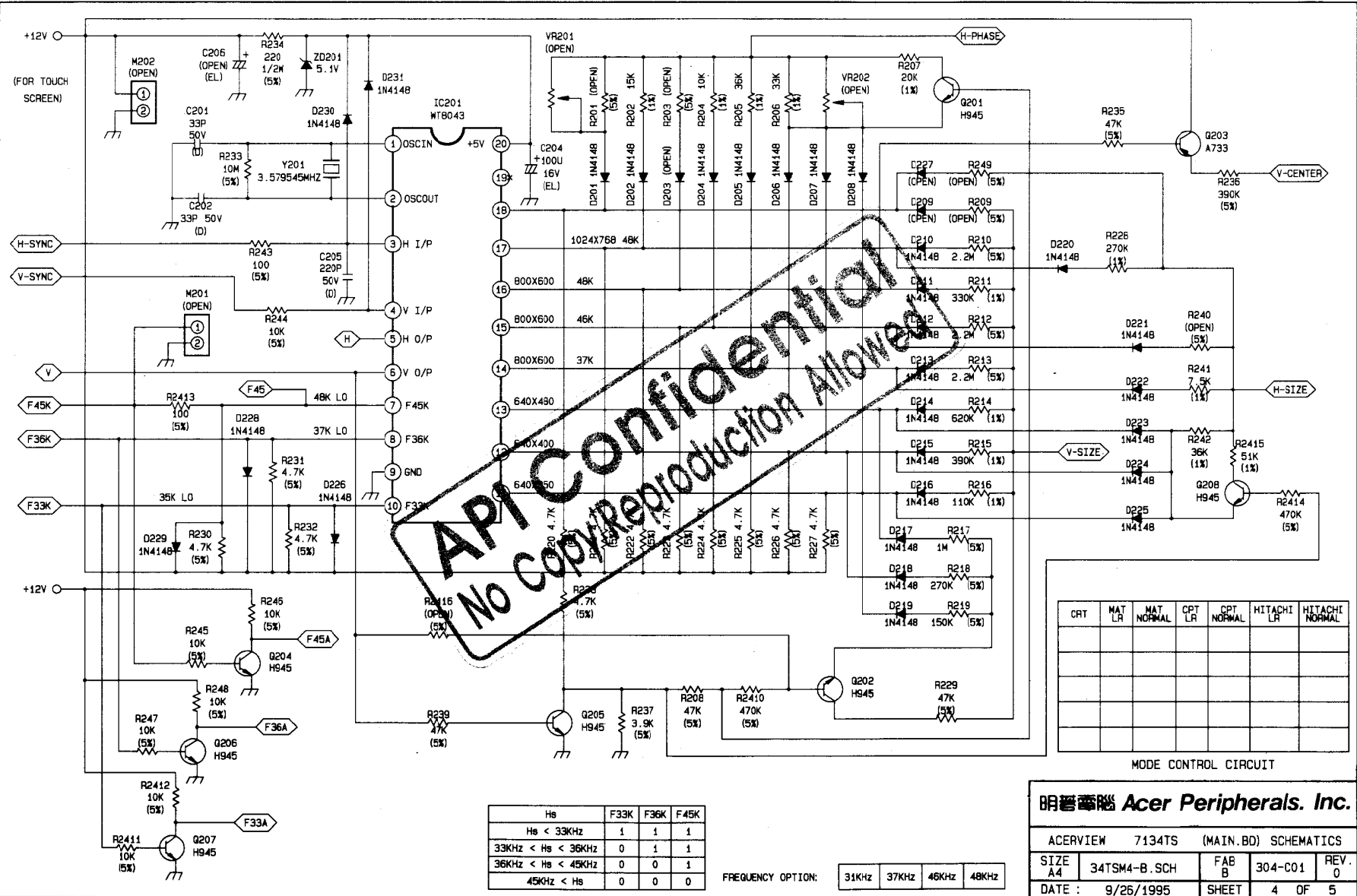

API Confidential  
No Copy/Reproduction Allowed

CRT	MAT LR	MAT NORMAL	CPT LR	CPT NORMAL	HITACHI LR	HITACHI NORMAL

MODE CONTROL CIRCUIT

Hz	F33K	F36K	F45K
Hz < 33KHz	1	1	1
33KHz < Hz < 36KHz	0	1	1
36KHz < Hz < 45KHz	0	0	1
45KHz < Hz	0	0	0

FREQUENCY OPTION:    31KHz   37KHz   46KHz   48KHz

明碁電腦 **Acer Peripherals, Inc.**

ACERVIEW 7134TS (MAIN.BD) SCHEMATICS	
SIZE A4	34TSM4-B.SCH
DATE : 9/26/1995	SHEET 4 OF 5

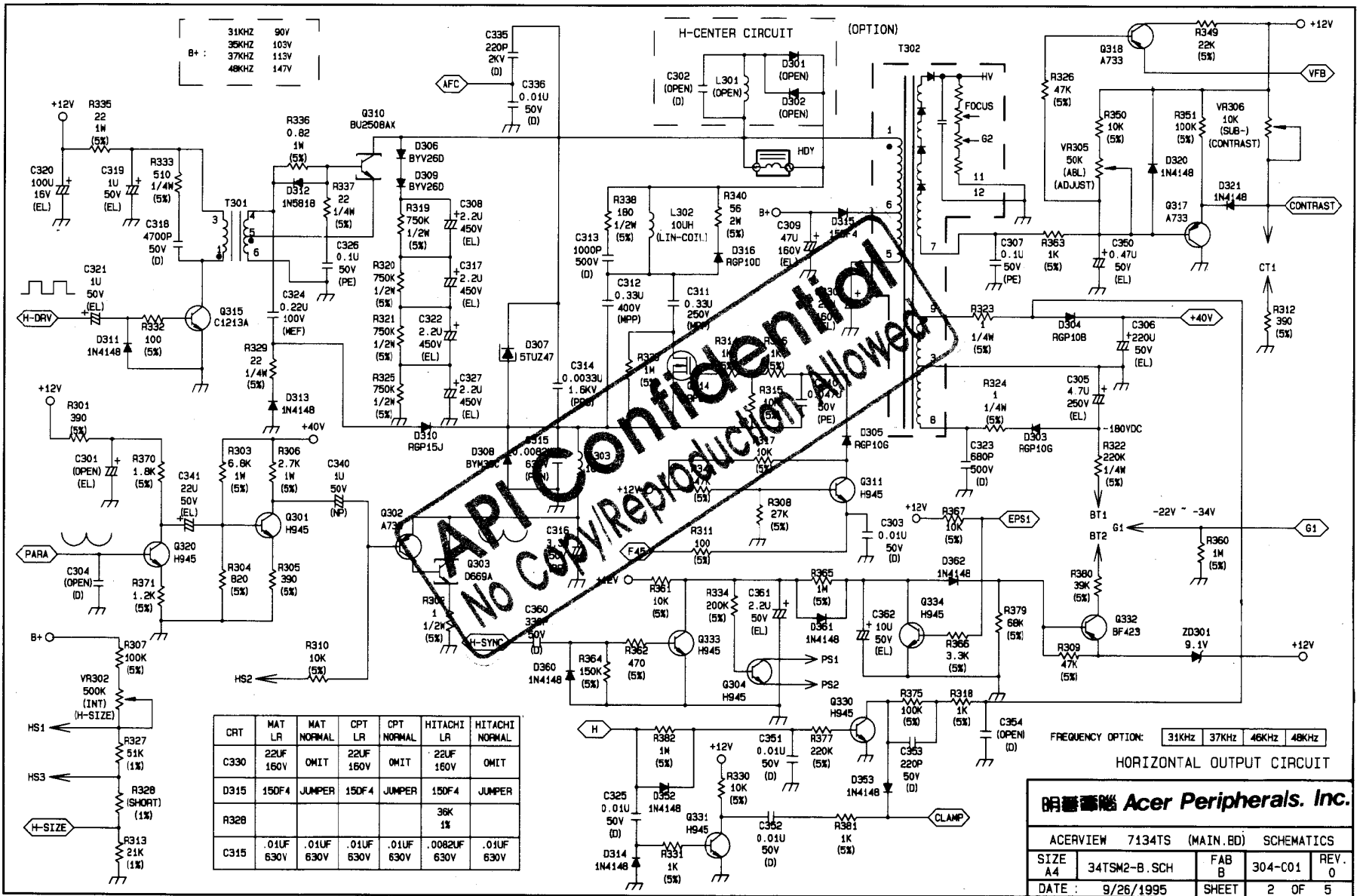

**明基電腦 Acer Peripherals, Inc.**

ACERVIEW 7134TS (MAIN.BD) SCHEMATICS

SIZE A4	34TSM2-B.SCH	FAB B	304-C01	REV. 0
DATE: 9/26/1995	SHEET	2	OF	5

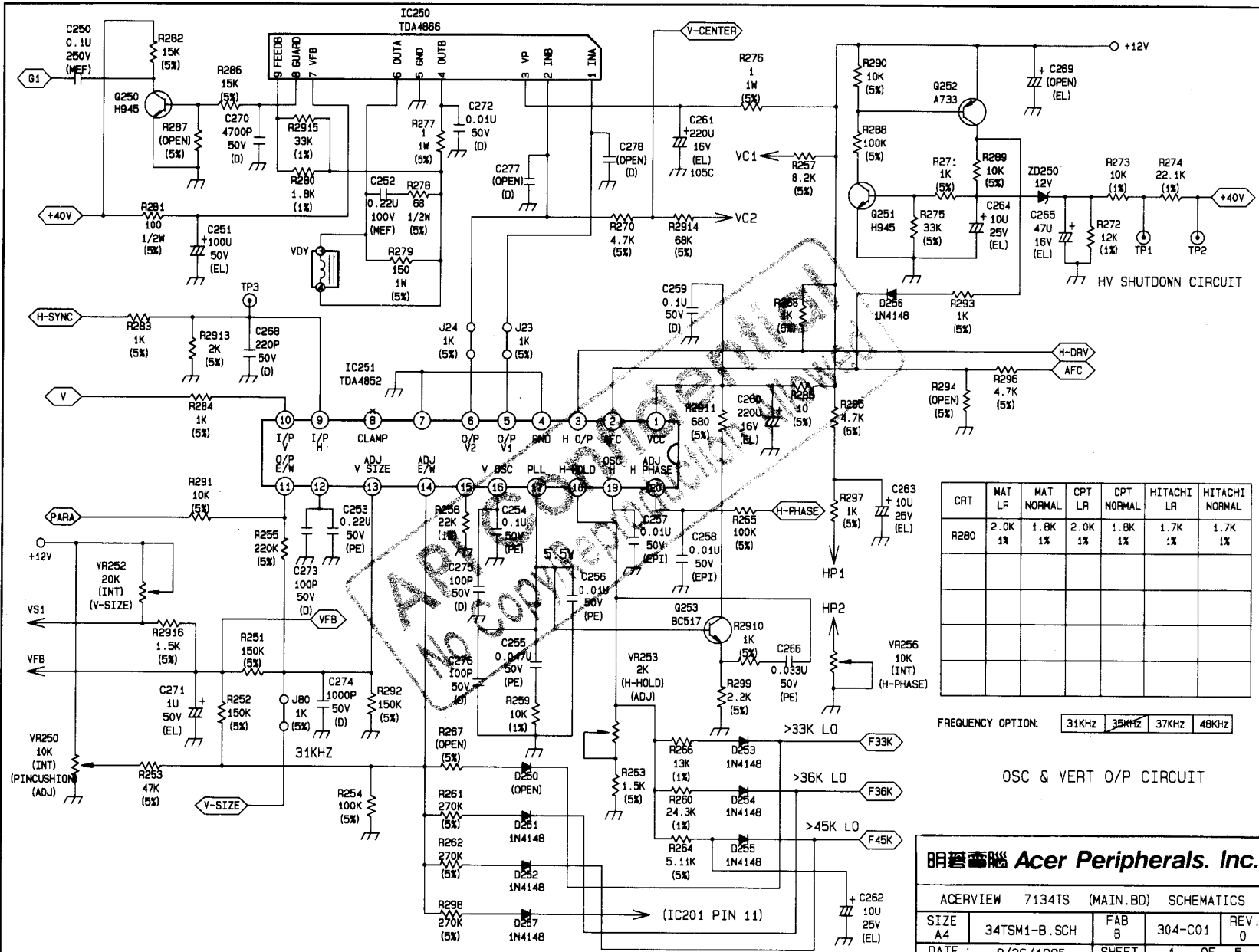



SIGNAL CABLE

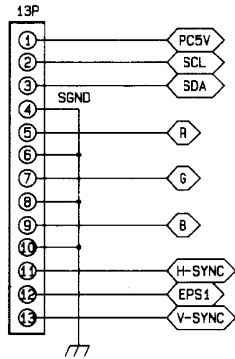

MAIN BOARD  
YOKE M302 7P

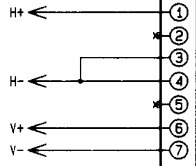

M204 10P

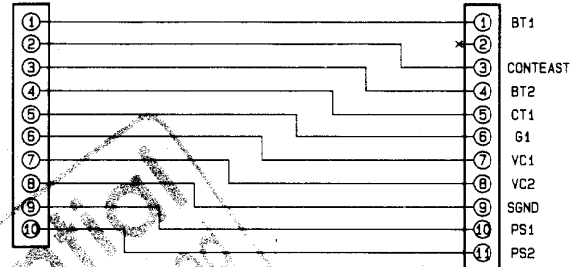

M203 9P

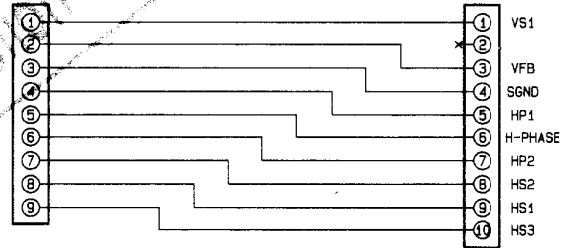

MAIN BOARD

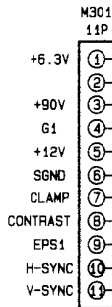

VIDEO BOARD

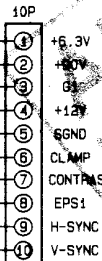

FREQUENCY OPTION:

31KHz 37KHz 46KHz 48KHz

CONNECTOR CIRCUIT

明碁電腦 Acer Peripherals, Inc.

ACERVIEW 7134TS (MAIN.BU) SCHEMATICS				
SIZE A4	34TSM3-B.SCH	FAB B	304-C01	REV. 0
DATE :	9/26/1995	SHEET	3 OF	5